

Introduction

The CFA has advantages over the VFA. Why not avail yourself of them?

The current feedback amplifier (CFA) has the same ideal closed-loop equations as the voltage feedback amplifier (VFA), but the CFA offers three improvements when compared with the VFA. Generally, CFA's cost less per megahertz of bandwidth, and they don't have the constant gain-bandwidth or slew rate limitations of the VFA. As a result, the CFA's open-loop gain doesn't roll off until much higher frequencies. That typically makes the CFA the amplifier of choice for high-frequency op-amp circuits.

On top of that, the input circuit of the CFA supplies current to the output under transient conditions, and this extra current increases the slew rate. In fact, the CFA often is the best circuit available with its cost-effective combination of high gain, high performance, and low I_{CC} . Substituting a CFA for a VFA in the design or production stages will result in better performance and lower cost. The rather straightforward mechanics of the substitution are detailed here.

Understanding the CFA

In a CFA model, it can be seen that the noninverting input is connected to the input of a unity gain, which usually takes the form of sophisticated emitter follower circuit, and is modeled by G_B and Z_B (Figure 1). Because the noninverting input is actually the input of a buffer, it's a high-impedance input. Also, because this buffer's output connects to the inverting input, CFAs have a lower inverting-input impedance, Z_B . The inverting-input impedance will be very low (as low as 10Ω). Therefore, the open-loop inverting-input impedance is about equal to $(Z_G + Z_B)$, which ranges from $1k\Omega$ to 10Ω .

G_B possesses a bandwidth greater than the remainder of the amplifier, coupled with a gain that is very close to one, so it is neglected in the calculations. On the other hand, Z_B is a function of frequency and has a secondary effect on stability, so it must be included in the calculations. The current I , flowing through the inverting input generates a voltage that is equal to the current times the transimpedance, Z . This voltage is modeled by the output voltage source, $Z(I)$. This voltage becomes the output voltage after passing through the output buffer, which is modeled by G_{OUT} and Z_{OUT} . Again, G_{OUT} will be neglected for the same reasons that G_B was neglected. Z_{OUT} is a function of frequency and can have an effect at higher frequencies under capacitive-load conditions, but it will be neglected because these effects are easily calculated and are minimal under normal loading.

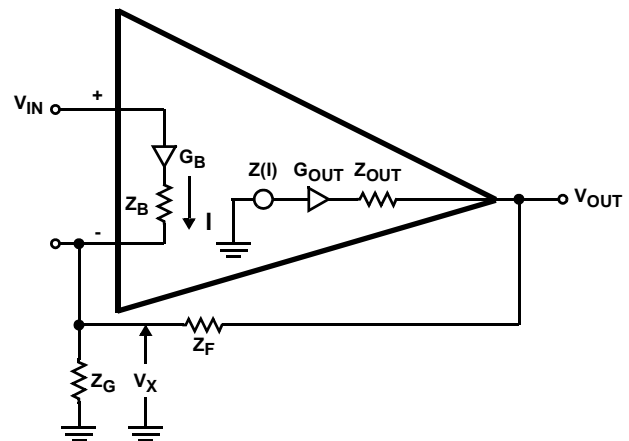

FIGURE 1. MODEL OF A CURRENT FEEDBACK AMPLIFIER (CFA)

An abbreviated development of the noninverting circuit equations is given here; the complete development of the CFA equations is available in many other sources[1]. Equation 1 is the current equation at the inverting input of the circuit shown in Figure 1. Equation 2 is the loop equation for the input circuit, and Equation 3 is the output circuit equation. Applying some algebraic manipulation to these equations yields Equation 4, which is the noninverting closed-loop circuit equation. Equation 5 is the standard feedback equation where A is the direct gain and β is the feedback factor[2].

$$I = \frac{V_X}{Z_G} - \frac{(V_{OUT} - V_X)}{Z_F} \quad (\text{EQ. 1})$$

$$V_X = V_{IN} - IZ_B \quad (\text{EQ. 2})$$

$$V_{OUT} = IZ \quad (\text{EQ. 3})$$

$$\frac{V_{OUT}}{V_{IN}} = \frac{\frac{Z(1 + Z_F/Z_G)}{Z_F(1 + Z_B/Z_F \parallel Z_G)}}{1 + \frac{Z}{Z_F(1 + Z_B/Z_F \parallel Z_G)}} \quad (\text{EQ. 4})$$

$$\frac{V_{OUT}}{V_{IN}} = \frac{A}{1 + A\beta} \quad (\text{EQ. 5})$$

If A is so large that the product $A\beta$ is much greater than one, then the ideal closed-loop gain is equal to $1/\beta$. Also, the stability[3] of Equation 5 is determined by its denominator, or, in other words, by $A\beta$. As the transimpedance, Z , in Equation 4 approaches infinity, the ideal closed-loop gain becomes $G = 1 + Z_F/Z_G$, which is identical to the VFA noninverting

ideal closed-loop gain. This presents a paradox: If the ideal closed-loop gains are identical, then how does the CFA become independent from the constant-gain-bandwidth limitation of the VFA?

If the input buffer were perfect, the quantity Z_B in Equation 4 would be zero, and Equation 4 becomes Equation 6 as shown.

$$\frac{V_{OUT}}{V_{IN}} = \frac{Z(1 + Z_F/Z_G)}{Z_F \left(1 + \frac{Z}{Z_F} \right)} \quad (\text{EQ. 6})$$

A close inspection of Equation 6 indicates that the CFA has the same ideal closed-loop gain as the transimpedance gets very large, but Z_G is eliminated from the denominator when Z_B is zero. The stability is determined by the denominator, and the denominator is independent of Z_G . Thus, the stability is independent of the closed-loop gain, and the constant-gain-bandwidth limitation doesn't exist.

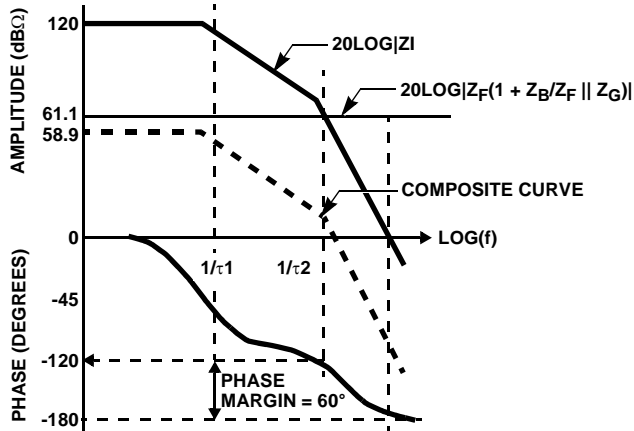

FIGURE 2. THROUGH LOG (BODE) PLOTS OF STABILITY FOR A CFA, THE CIRCUIT DESIGNER CAN MANIPULATE INDEPENDENT VARIABLES SEPARATELY TO ANALYZE THEIR INDIVIDUAL EFFECTS

The equation for the inverting configuration is developed with the same techniques used to develop the noninverting equation and is given as Equation 7. Notice that the denominators of Equations 4 and Equation 7 are identical. This is because stability depends solely on the loop gain, $A\beta$, given in Equation 8, and not on the placement of the inputs.

$$\frac{V_{OUT}}{V_{IN}} = -\frac{Z}{Z_G(1 + Z_B/Z_F || Z_G) \left(1 + \frac{Z}{Z_F(1 + Z_B/Z_F || Z_G)} \right)} \quad (\text{EQ. 7})$$

$$A\beta = \frac{Z}{Z_F(1 + Z_B/Z_F || Z_G)} \quad (\text{EQ. 8})$$

Stability and Resistors

Equation 9 gives the criteria for stability, but there several methods for evaluating this criteria. The method used in this article is called the Bode plot[4], which is a log plot of the stability equation. A brief explanation of the Bode-plot procedure is provided in the publication Feedback, Op Amps and Compensation[5].

The magnitude and phase of the open-loop transfer function are both plotted on logarithmic scales, and if the gain declines below 0dB before the phase shift reaches -180° , the circuit is stable. In practice, the negative phase shift should be $\leq 140^\circ$, or greater than 40° phase margin, to obtain a well behaved circuit.

$$1 + A\beta = 0 \text{ or } A\beta = -1 = |1| \angle -180^\circ \quad (\text{EQ. 9})$$

$$20 \log |A\beta| = 20 \log \left| \frac{Z}{Z_F (1 + Z_B/Z_F || Z_G)} \right| \quad (\text{EQ. 10})$$

$$\phi = \text{Tangent}^{-1} \frac{Z}{Z_F(1 + Z_B/Z_F || Z_G)} \quad (\text{EQ. 11})$$

The answer to the stability question is found by plotting these functions on log paper. The stability equation $20 \log |A\beta|$, for the CFA has the form $20 \log(x/y)$, which can be written as $20 \log(x/y) = 20 \log(x) - 20 \log(y)$. The numerator and denominator of Equation 10 will be operated on separately, plotted independently, and then added graphically for analysis. Using this procedure, the independent variables can be manipulated separately to show their individual effects. This is given in a plot of Equation 10 for a typical CFA, where $Z = 1M\Omega (\tau_1 S + 1) (\tau_2 S + 1)$; $Z_F = Z_G = 1k\Omega$; and $Z_B = 70\Omega$ (Figure 2).

If $20 \log |Z_F(1 + Z_B/Z_F || Z_G)|$ were equal to 0dB, the circuit would oscillate because the phase shift of Z reaches -180° before $20 \log |Z|$ falls below 1. Because $20 \log |Z_F(1 + Z_B/Z_F || Z_G)| = 61.1 \text{ dB}\Omega$, the transimpedance curve moves down by that amount to $58.9 \text{ dB}\Omega$, where it's stable because it has -120° phase shift or 60° phase margin. Notice that when Z_F approaches zero (represented by a short circuit from the output to negative input), which is typical of a unity gain VFA, $A\beta = Z/Z_B$, and because Z_B is very small, the circuit tends to become unstable.

This explains why the CFA, when configured in a noninverting gain of one circuit, must have a properly selected feedback resistor to prevent oscillations. Placing diodes or capacitors across or in place of the feedback resistor will cause oscillations because they simulate good short circuits at some point in their transfer functions. Remember that oscillation is always preceded by overshoot and ringing as the phase margin decreases, so if the circuit has too much overshoot, the stray feedback capacitance may be too high, or R_F may be too low. If $Z_B = 0\Omega$ and $Z_F = R_F$, then $A\beta = Z/R_F$. In this special case, stability is only a function of Z and R_F , and R_F can be specified to guarantee stability.

The first conclusion drawn here is that $Z_F(1 + Z_B/Z_F \parallel Z_G)$ impacts stability, and that because the feedback resistor is the preeminent part of that quantity, it has the dominant impact on stability. The dominant selection criteria for R_F is to obtain the widest bandwidth with an acceptable amount of peaking: 60° phase margin is equivalent to about 10% overshoot. The second conclusion is that the input buffer's output impedance, Z_B , will have a minor effect on stability because it's small compared to the feedback resistor, even though it is multiplied by $1/Z_F \parallel Z_G$.

Rewriting Equation 8 as $A\beta = Z(Z_F + Z_B(1 + R_F/R_G))$ leads to the third conclusion, which is that the closed-loop gain has a minor effect on stability and bandwidth because it's multiplied by Z_B , which is a small quantity relative to Z_F . It's because of this third conclusion that many people claim closed-loop gain versus bandwidth independence for the CFA, but that claim depends on the value of Z_B relative to Z_F .

The manufacturer selects optimum values for R_F during circuit characterization, but different R_F values can be selected for each different closed-loop gain to yield the best transient performance. An easy way to select a new value of R_F is to review the manufacturer's data sheet and interpolate or extrapolate to determine R_F and bandwidth values outside those given by the manufacturer.

Real-Life Conversions

Most VFA-to-CFA conversions are made in the initial design stages, but the cost and performance advantages of CFAs can dictate that conversions occur while in production. Because the ideal closed-loop equations are identical, it's possible to directly substitute a CFA in a VFA socket with no PC board changes. When the direct substitution happens, it's because the VFA circuit used a feedback resistor, and good grounding and power-distribution techniques aided the board layout.

Several in-production substitutions have been undertaken because CFAs are less expensive for high-frequency applications. All direct substitutions require extensive testing before the new design hits production.

Sometimes it's impossible to implement a direct substitution either because R_F wasn't included in the original design, feedback capacitors were used, or R_F was paralleled by diodes. In these cases, the circuit will have to be modified so that R_F can control the stability. Diodes in the feedback loop often can be replaced by input or output clamp diodes, and feedback capacitors can be neutralized by putting a resistance in series with them. Or, they could be replaced by other filtering techniques.

The integrator configuration is especially hard for a CFA to perform because it requires a feedback capacitor. This can be done, however, by placing the capacitor in the CFA's positive-input circuit or by buffering the capacitor with another amplifier.

The bias currents in a CFA aren't correlated like they are in a VFA. The VFA uses a differential-transistor pair in the input, and because the differential pair is matched, its bias currents also are matched. Applications using VFAs can take advantage of the matched bias currents to cancel them so that the resulting circuit only sees the difference in the bias currents as an error source. CFA inputs are the input and output of a buffer. This means that the positive input current is really a bias current, while the negative input current is the buffer's output current. Manufacturers attempt to minimize the inverting-input current because it generates an offset voltage by flowing through R_F . In most cases, noninverting input current isn't critical in high-frequency amplifier circuits because low source impedances keep the voltage generated by the input currents low. There is little need for DC precision in high frequency circuits, so the small DC offset is acceptable. The CFA and VFA have similar offset voltages, so this isn't a problem in precision design.

Watch Layout

Any high-frequency circuit requires attention to layout details, and CFA circuits are no exception. Remember, the criteria for referring to an amplifier as "high frequency" is its maximum bandwidth, not the signal frequency or function it performs.

The first criteria of a good layout is a solid ground plane for low-impedance current-return paths that will prevent the return currents from generating noise. This conflicts with the requirement that the stray capacitance associated with the inverting input, C_{IN} , be kept low to prevent peaking. Equation 8 shows that the value of Z_G is critical to stability, and any capacitance added to the inverting node will push the circuit toward instability (Figure 3). There's less than 1dB peaking when C_{IN} or C_F equal zero. However, when either of these capacitors reaches just 2pF, the peaking is increased by 3dB or more. The way to minimize the node capacitance is to cut away the ground plane under the inverting input and under the traces connected to this node.

This chops up the ground plane slightly, but the noise increase is minimal if it's done correctly.

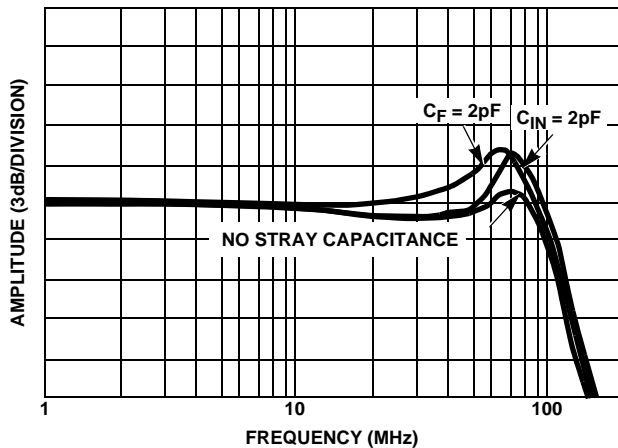

FIGURE 3. THE EFFECTS OF STRAY CAPACITANCE ON THE CLOSED-LOOP PERFORMANCE OF A CFA

The IC manufacturer must create good layouts to characterize the CFA. These layouts are typically made available to customers in the form of evaluation boards and artwork. It's very important to initially evaluate a new CFA on the manufacturer's supplied evaluation board. That way, you have a common test bed with the application engineers who characterized the device. If problems or questions arise, the application engineer can quickly emulate or duplicate them on another evaluation board.

Don't be afraid to modify the evaluation boards as required to suit your needs; they will still serve as the platform for getting your design off the ground. The artwork that generates the evaluation boards (Figure 4) contains many engineering hours, and because it isn't copyrighted, you may feel free to use it in your next design. Most IC manufacturers encourage the use of their evaluation-board artwork in a customer's product.

The worst noise sources on a PC board are the logic chips. Be careful when selecting a logic family: Some generate 50mA current spikes when their outputs change state, CMOS families included. These current spikes will generate voltage noise in the ground system, and CFAs have enough bandwidth to amplify the resultant voltage spikes. Analog signals should never be run parallel to digital signals because the edges in the digital signals will inject crosstalk into the analog lines, which creates noise in the analog signals. If PC board-density requirements force you to run analog signals in parallel with digital signals, they should be separated by a trace grounded at one end. The grounded trace acts as a Faraday shield that shunts the digital edges to ground.

Capacitive loads often will make amplifiers ring or oscillate. This can be prevented by inserting a small resistor (27Ω is a good starting value) in series with the output. The isolation resistor will be most effective if it's placed outside the

feedback loop, but it forms a low-pass filter with the load capacitor (Figure 5) and introduces gain errors if driving low resistance loads. If the resistor is put inside the feedback loop, there's little or no filtering effect, and the feedback eliminates the gain error. This technique, however, doesn't work for all amplifiers. In either case, extensive testing is required to determine the correct value. Remember to allow for manufacturing tolerances by choosing a larger resistor than seems necessary.

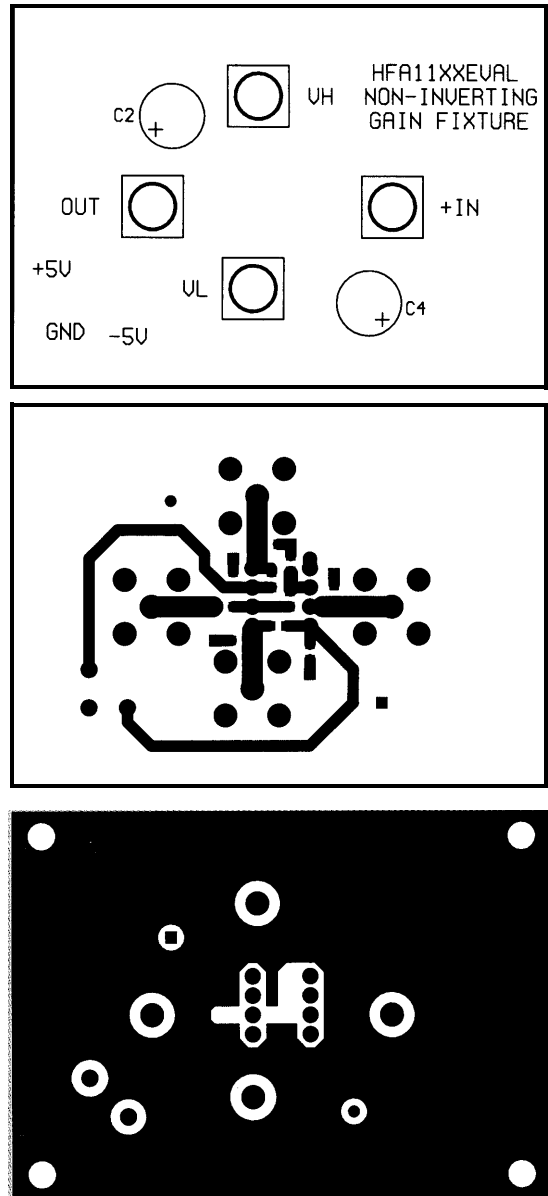

FIGURE 4. EXAMPLE CFA EVALUATION BOARD ARTWORK

All active circuits must be decoupled with a good grade of 0.01 μ F ceramic capacitor. This capacitor circulates return currents at the IC, thus, preventing noise generation. It also acts as a power-supply filter. At high frequencies, the circuit trace between the IC and the power supply acts like a nanohenry-value inductor, so the decoupling capacitor may be your only defense against locally generated noise.

One last item to consider is the selection of the CFA's companion components. Leadless components are preferred because their low lead inductance won't impede high-frequency performance. Components must be small so they can be placed as close as possible to the IC to keep traces short. Also, ensure that the components' self-resonant frequency is much higher than the amplifier's bandwidth. That way, the components will work correctly until the CFA transimpedance has decreased enough to preclude oscillation.

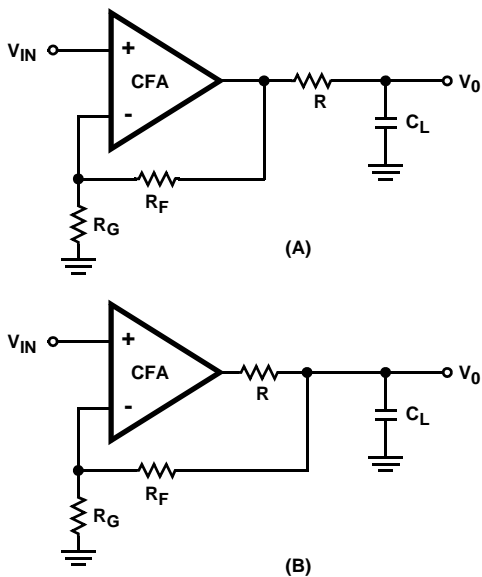

FIGURE 5. TWO METHODS FOR TAMING LOAD CAPACITANCE EFFECTS: (A) ISOLATION RESISTOR OUTSIDE THE FEEDBACK LOOP. (B) RESISTOR INSIDE THE FEEDBACK LOOP.

AC Precision

The error signal expressed as a function of the loop gain for any feedback system is equal to $V_{IN}/A\beta$ for $A\beta \gg 1$:

$$\text{Error} = V_{IN}/(1 + A\beta) \quad (\text{EQ. 12})$$

Consider the HA502X[6] family of CFA ICs in a noninverting gain of +2: $Z = 6\text{M}\Omega$, $R_F = R_G = 1\text{k}\Omega$, and $R_B = 75\Omega$. Also, $A\beta = 6,000,000/1000(1 + 75/500) = 5217$. Then the error = $1/5217$ or 0.019%. Or conversely, the system is accurate to 12.4 bits because $N = 1.45\text{Ln}(5217)$. The HA2841[7] is a high-frequency VFA with accuracy of 15.7 bits at DC. Now consider the same amplifiers at a gain of 10 and a frequency of 1MHz. The CFA's parameters are $Z = 40\text{k}\Omega$, $R_F = 383\Omega$,

and $R_G = 42.5\Omega$, so $A\beta = 35.3$. This means the accuracy is equivalent to a 5.16-bit system. The same VFA has a loop gain of 10dB at 1MHz, which corresponds to an accuracy of 1.69 bits. Although the DC accuracy of CFAs is lower than that of the VFA at low frequencies, it surpasses the accuracy of VFAs at higher-gain/frequency applications.

Amplifier Noise

All amplifiers generate internal noise, which they amplify and pass on to other circuits in the signal chain. The input-voltage noise level is comparable in the CFA and the VFA, and in both cases is multiplied by the ideal closed-loop gain. The input-current noise is higher for the CFA, but it doesn't always result in a higher overall-circuit voltage noise because the resistances for CFAs are typically lower.

The noninverting-input current noise is approximately $2.5 \text{ pA}/(\text{Hz})^{1/2}$, which is lower than the inverting-input current noise of about $25 \text{ pA}/(\text{Hz})^{1/2}$. Because the positive input is typically terminated in 75Ω or less, the voltage noise contribution attributed to the current noise is 187.5 pV . The inverting input current noise is the troublemaker because it's bigger and is multiplied by the feedback resistor. With feedback resistors approaching $1\text{k}\Omega$, the resultant noise voltage at the circuit output is $25 \text{ nV}/(\text{Hz})^{1/2}$. One way to minimize this noise is to choose CFAs that specify a very low feedback-resistor value.

Conclusion

In conclusion, the CFA can easily replace the VFA in most high-frequency applications with better performance and lower cost. There are just a few salient points to be aware of during the replacement, and most cases will require either minor or no PC-board changes. But remember that the CFA must have a feedback resistor, thus a CFA can't be substituted directly for a VFA in unity-gain applications in which the output is shorted to the inverting input ($R_F = 0$).

The key to CFA stability is the feedback resistor. A value of R_F that yields stable operation can always be found. It's best to start with the manufacturer's recommended value, but graphical techniques can be used to select new R_F values if wider bandwidth or a new closed-loop gain is desired. Remember, lower R_F increases bandwidth while increasing ringing and overshoot. Don't drop the value of R_F too much or oscillation will result.

The CFA is optimized for high frequency tasks but not for low-frequency precision work. Although new CFAs have improved precision parameters, there's rarely any advantage in using a high-frequency amplifier when a low-frequency one will do. An exception is when the high-frequency amplifier is bandwidth-limited by an external component to achieve AC stability. The VFA has the higher precision at DC, but as frequency increases, the CFA ends up with the highest precision. This is especially true in high-gain applications.

As with all high-frequency amplifiers, PC-board layout is critical. At one time, it was said that a good layout could gain an extra 10% in bandwidth. Now, an excellent layout is required to achieve stability, and the bandwidth will be a direct function of the layout and the CFA. Peripheral components should also be chosen carefully, because they also contribute to the frequency response.

The CFA doesn't have a constant-gain-bandwidth limitation, so it can be optimized for bandwidth at each new gain. The optimization is implemented by selecting the feedback resistor. Basically speaking, the CFA is no harder to use than a VFA with equivalent bandwidth; it's just a little different.

References

- [1] Mancini, R. and Lies, J., Current Feedback Amplifier Theory and Applications, Intersil Corporation, 1995.
- [2] Mancini, R., Feedback, Op Amps and Compensation, Intersil Corporation, 1995.
- [3] Ibid.
- [4] Bode, H.W., Network Analysis and Feedback Amplifier Design, D. Van Nostrand Inc., 1945.
- [5] Mancini, R., Feedback, Op Amps and Compensation, Intersil Corporation, 1995.
- [6] Data sheet for HA5020, Intersil Corporation, 1995.
- [7] Data sheet for HA-2841 Intersil Corporation, 1995.

All Intersil U.S. products are manufactured, assembled and tested utilizing ISO9000 quality systems. Intersil Corporation's quality certifications can be viewed at www.intersil.com/design/quality

Intersil products are sold by description only. Intersil Corporation reserves the right to make changes in circuit design, software and/or specifications at any time without notice. Accordingly, the reader is cautioned to verify that data sheets are current before placing orders. Information furnished by Intersil is believed to be accurate and reliable. However, no responsibility is assumed by Intersil or its subsidiaries for its use; nor for any infringements of patents or other rights of third parties which may result from its use. No license is granted by implication or otherwise under any patent or patent rights of Intersil or its subsidiaries.

For information regarding Intersil Corporation and its products, see www.intersil.com